

T2 MINI
POS User Manual Book

Before using this product, please carefully read this manual and keep it properly.

Guide for quick installation

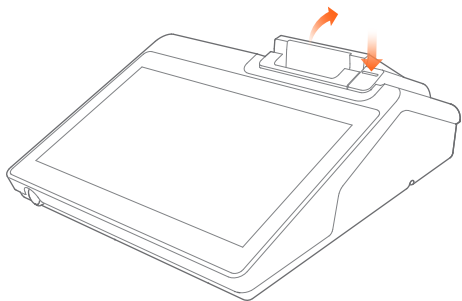

1 Press the open button to open the cover of the printer.

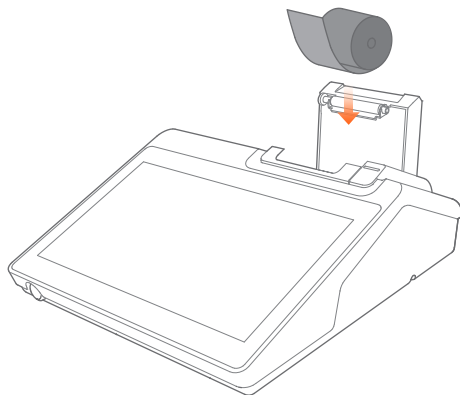

2 Place the thermal paper in the printer.

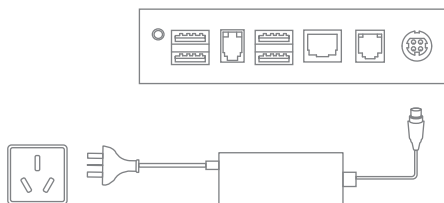

3 Connect with the power supply.

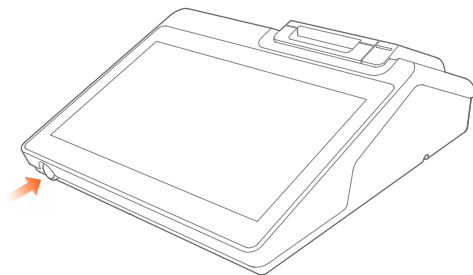

4 Press ON button and the printer will be turned on in two seconds.

Simple Settings

To start this intelligent device for commercial use, you only need several steps.

- 1** Press ON button to light the screen. First entering the startup screen, follow the prompts. You can choose from two network modes on this device.
- 2** Wi-Fi settings
 - Click "Settings" button and open WLAN to enter the WLAN-searching interface. Wait for the list of available WLAN hotspots.
 - Click corresponding WLAN. If an encrypted network is selected, the device will not be connected to the WLAN until the password is entered.
- 3** LAN settings

How to download/use APPs

Relevant Apps can be downloaded while the network is connected. Open the App market, and search and download the App to complete the installation.

To inquire detailed information of the above software: select "settings -> application", and select corresponding software to inquire its information;
how to uninstall the software: select "settings -> application -> application management -> uninstall" to uninstall the application; or press the icon and drag it into the trash can to uninstall it.

For more help, please refer to the Help App inside the device

Introduction to the POS

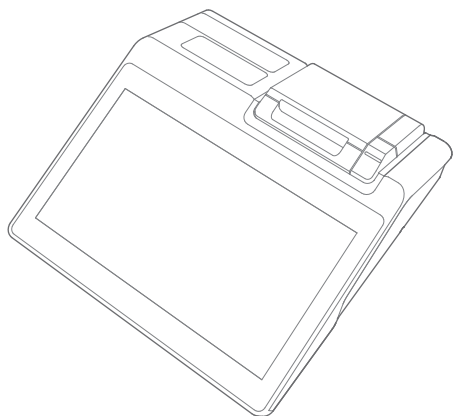

58 thermal printer version
(L1320)



80 thermal printer version
(L1322)

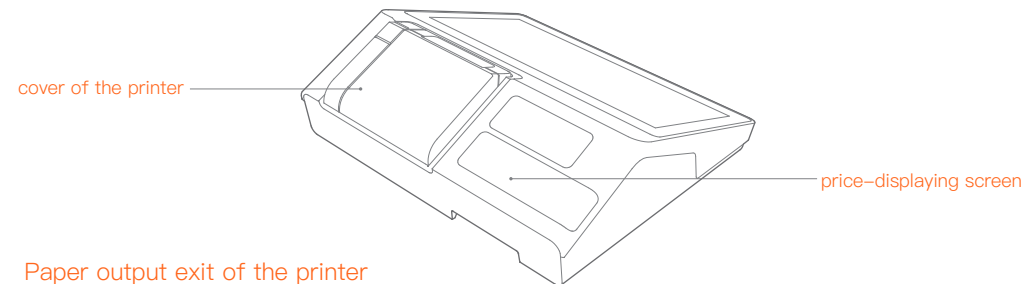
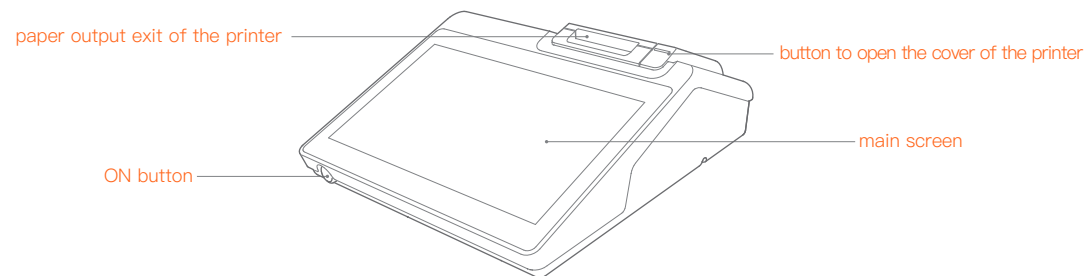

Paper output exit of the printer

It is used to print receipts when the device is on.

Button to open the cover of the printer

It is used to open the cover of the printer and change the paper.

Main screen

It is the touch screen used by the operator.

ON button

While the device is off, click the ON button to turn on the machine;
While the device is under use, press ON button for 2 to 3 seconds to turn on or turn off the device.
While the device is on, press ON button for 11 seconds to turn off the device.

Price-displaying screen

It is used for displaying the price information of the customer.

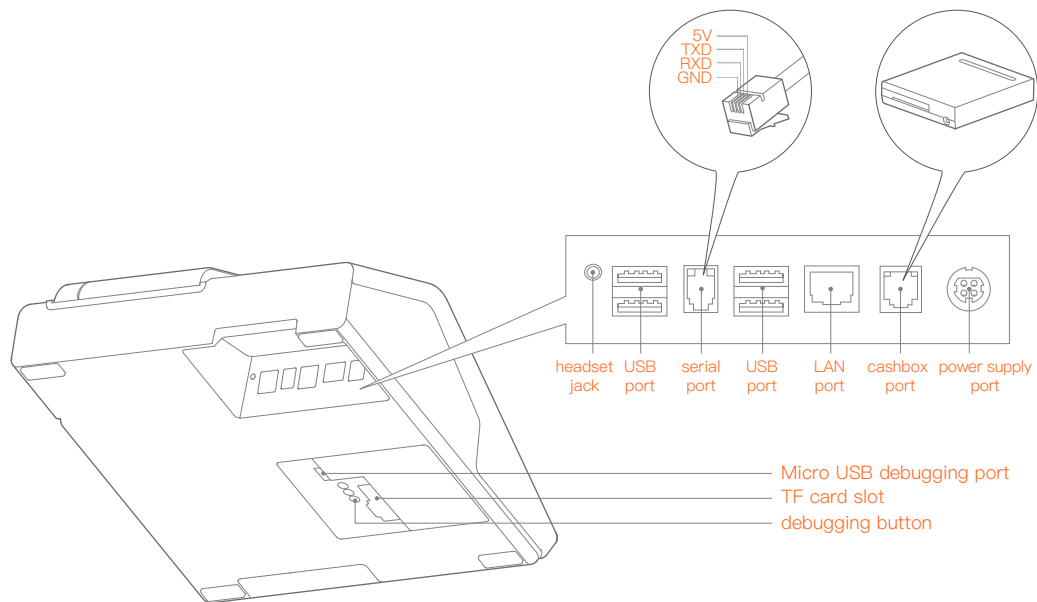

TF card slot

It is used for external expansion TF memory card.

Micro USB debugging port, debugging button

They are used to debug the device.

Cashbox port

It is used to connect the cashbox, with an electrical impulse of 120ms and no continuous power supply being provided. This device only supports external connection with 24V/1A cashbox. If 12V cashbox is used, there may be risks that the circuit of the cashbox will be burnt.

Instruction to load paper

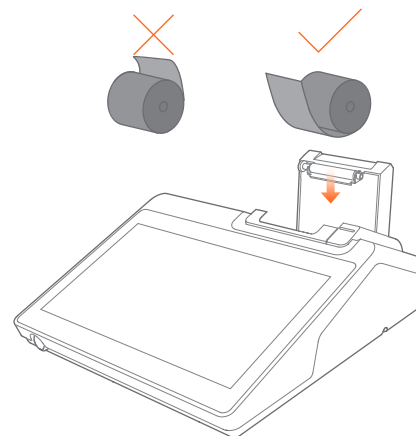

Description of the paper

58 version supports the thermal paper with the size of $57\pm 0.5\text{mm}\times\text{Ø} 60\text{mm}$;

80 version supports the thermal paper with the size of $79\pm 0.5\text{mm}\times\text{Ø} 60\text{mm}$.

Regular fault debugging

Problems	Solutions
What if the printer is dead?	Press the ON button for 11 seconds, then the printer is off. Click the ON button to turn the printer on.
What if the printer does not work?	Make sure the cover is closed correctly. Make sure whether the paper is jammed.
What if the printed paper is blank?	Please check whether the paper roll is put upside down; Please check whether wrong thermal paper roll is used.
What if the printing is blur?	Please check whether the thermal printhead is dirty. If it is, please clean it with swab that has been dipped in anhydrous alcohol. Please use quality thermal paper to avoid blur printing due to bad quality of paper.

Precautions

Warning

- Please insert the AC plug into the AC outlet according to the identifying input on the power adapter;
- It is prohibited to use the device in any places with potential explosive gases;
- Nonprofessionals shall not open the power adapter anyhow so as to avoid dangers;
- The device is a Grade A product. In living environment, the product may cause radio interference. Therefore, users may be required to take practical measures against the interference.
- About the battery replacement:
 1. It may cause explosion with wrong type battery
 2. Old battery which is replaced should be handled by repair man, do not put it in fire!
- Adapter shall be installed near the equipment and shall be easily accessible.
- The operating temperature of the device between -10°C to 55°C.
- The device complies with RF specifications when the device used at 20cm from your body.
- This product can be used across EU member states.

Recommendation

- Do not use the device near water or in humid environment.Keep liquid from falling onto the terminal;
- Do not use the device in extremely cold and hot environment, e.g. around fire or lighted cigarettes;
- Do not smash, throw or bend the device;
- Use the device in clean and dustfree environment as much as possible and keep small items from falling into the terminal;
- Do not use it near medical devices unless permitted.

Important Safety Instructions

- Avoid installing or using during thunder and lightning,other wise lightning stroke may occur;
- Cut off the power immediately if there is abnormal smell, overheating or smog;
- Do not touch the sharp paper cutting tool!

Statement

The company is not responsible for the following behaviors:

- Damages caused by using and maintaining the device without following the User Guide;
- Damages or problems caused by selection of objects or consumables (products which are not the initial ones provided or recognized by the company);
- No one is entitled to modify or change the product unless permitted by the company;
- The operating system of this product supports the official system update.If the third party's ROM system is swiped by the user or the system file is modified with cracking method, it may lead to the instability of the system and bring about safety risk & security threat.

Disclaimer

Discrepancies between the product and the file concerning details may raise due to product updates. Please be subject to the material object. The company reserves the right to interpret the file and the right to revise this manual without prior notices.

Please make sure the temperature for adapter will be from -10 °C to 55 °C.

Please make sure the temperature for device will be from -10 °C to 55 °C.

EU Regulatory Conformance

Hereby, Shanghai Sunmi Technology Co., Ltd. declares that the radio equipment type is in compliance with Directive 2014/53/EU.

The full text of the EU declaration of conformity is available at the following internet address: www.sunmi.com

Notice: The device complies with RF specifications when the device used at least 20cm from human body.



FCC Regulations:

This device complies with part 15 of the FCC Rules. Operation is subject to the following two conditions:

(1) This device may not cause harmful interference, and (2) this device must accept any interference received, including interference that may cause undesired operation.

This device has been tested and found to comply with the limits for a Class B digital device, pursuant to Part 15 of the FCC Rules. These limits are designed to provide reasonable protection against harmful interference in a residential installation. This equipment generates, uses and can radiated radio frequency energy and, if not installed and used in accordance with the instructions, may cause harmful interference to radio communications. However, there is no guarantee that interference will not occur in a particular installation. If this equipment does cause harmful interference to radio or television reception, which can be determined by turning the equipment off and on, the user is encouraged to try to correct the interference by one or more of the following measures:

- Reorient or relocate the receiving antenna.
- Increase the separation between the equipment and receiver.
- Connect the equipment into an outlet on a circuit different from that to which the receiver is connected.
- Consult the dealer or an experienced radio/TV technician for help.

Caution: Changes or modifications not expressly approved by the party responsible for compliance could void the user's authority to operate the equipment. This equipment must be installed and operated in accordance with provided instructions and the antenna(s) used for this transmitter must be installed to provide a separation distance of at least 20 cm from all persons and must not be co-located or operating in conjunction with any other antenna or transmitter. End-users and installers must be provide with antenna installation instructions and transmitter operating conditions for satisfying RF exposure compliance.